

400 Size **STANDARD**  
CONFIGURATION # **25010**  
H2O Rated

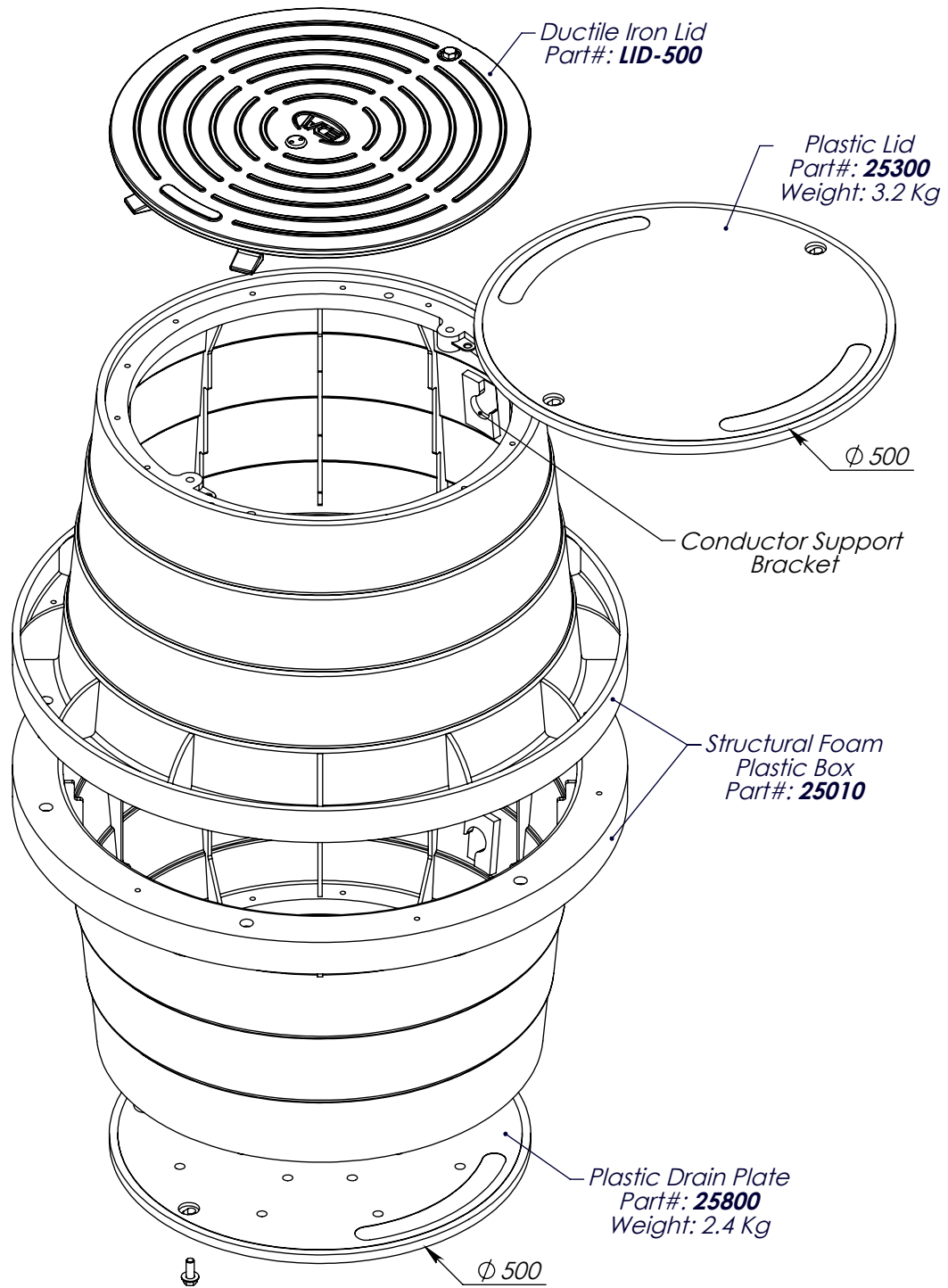

LARGE ROUND JUNCTION BOX  
**DUAL - Type 10** CONFIGURATION

DESIGNED:	ZOLTAN BANYI
DRAWN:	ZOLTAN BANYI
CHECKED:	JOAN GIOSAN
APPROVED:	TED BROCKMAN
DATE:	19/09/2014

PROFESSIONAL ENGINEER SEAL



**ANS**  
APPROACH NAVIGATION  
SYSTEMS INC. ✪

PROJECT:	Pulpit -400 ROUND 25010	SCALE:	NTS
DWG. #:	T01-JB-25010	QTY:	-
		SHEET	1 OF 1
		REV.	0