



LED ELEVATED RUNWAY GUARD LIGHT

LETG

OPERATING, INSTALLATION AND MAINTENANCE INSTRUCTION MANUAL

Drawn up by: E.RAULI

Approved by: M.ROMAGNOLI

No. of Attachments:

Copy no.:

Issue 03/09/2019

Suspended edition 05/11/2018

LETG - LED ELEVATED RUNWAY GUARD LIGHT

EDITIONS**Date**

16/10/2015 First Issue

REVISION HISTORY

Rev. No.	Date	Description	Author	Approved by
01	05/11/2018	Front image update, ICAO Sect. update, addition of spare parts and version E and L .	E.Berti	M.Mazzotti
02	03/09/2019	Updated Spare Parts Table	M.Bacciglieri	M.Mazzotti

LETG - LED ELEVATED RUNWAY GUARD LIGHT

TABLE OF CONTENTS

1	GENERAL INFORMATION	6
2	KEY FEATURES	6
2.1	Description of LETG light fixture	6
2.2	Input power.....	6
2.3	Operating conditions.....	7
3	FIXTURE TYPE IDENTIFICATION	8
4	INSTALLATION	9
4.1	External synchronization with double lead power supply.....	10
4.2	Low Installation Profile.....	10
5	AZIMUTH AND ZENITH ANGLE ADJUSTMENT	10
6	MAINTENANCE	12
6.1	Periodic checks.....	12
6.2	Non-scheduled maintenance	13
6.3	REPLACEMENT.....	13
6.3.1	Replacing lens and gasket.....	13
6.3.2	Replacing the LED board	13
6.3.3	Replacing the power supply board (power supply board assembly)	13
6.3.4	Replacing the power supply cable with connector.....	14
7	TROUBLESHOOTING	15
8	WIRING DIAGRAMS	16
9	SPARE PARTS	22

LIST OF FIGURES

Figure 1 - Overall dimensions	7
Figure 2 - P/N explanation.....	8
Figure 3 - Installation on FAA L-867 base plate and base plate	9
Figure 4 – LETG installation in low installation profile.....	10
Figure 5 - Horizontal and vertical aiming indexes	11
Figure 6 - Series power supply unit housing	14
Figure 7 - Housing of parallel power supply unit with dusk sensor	14
Figure 8– Non-monitored series circuit power supply.....	16
Figure 9– Non-monitored series circuit power supply with switch	16
Figure 10– Monitored series circuit power supply	17
Figure 11– Monitored series circuit power supply with switch	17
Figure 12– Non-monitored parallel circuit power supply with or without photocell.....	18
Figure 13– Non-monitored parallel circuit power supply with switch, with or without photocell	18
Figure 14– Monitored parallel circuit power supply with or without photocell.....	19
Figure 15– Monitored parallel circuit power supply with switch, with or without photocell	19
Figure 16 - Non-monitored series circuit power supply with external synchronization.....	20
Figure 17 – Wiring diagram for connection of monitored LETG to transformer.	21

LIST OF TABLES

Table 1 - Consumption	7
Table 2 - Weight and Volume of LETG.....	7
Table 3 -Periodic checks	12
Table 4 - Troubleshooting	15

Issue 03/09/2019

Suspended edition 05/11/2018

LETG - LED ELEVATED RUNWAY GUARD LIGHT

PRODUCT WARRANTY TERMS AND CONDITIONS

THIS WARRANTY IS THE SOLE WARRANTY MADE BY THE MANUFACTURER AND REPLACES ANY OTHER WARRANTIES, EXPRESS, IMPLIED OR STATUTORY, INCLUDING, BUT NOT BY WAY OF LIMITATION, ANY WARRANTIES OF MERCHANTABILITY OR FITNESS FOR A PARTICULAR PURPOSE.

OCCEM - ENERGY TECHNOLOGY warrants to the direct purchaser of the products manufactured by the Company that such products are free from defects in material at the time of delivery to the Purchaser, provided that no warranty is made with respect to:

- (a) any products that, in the Company's judgement, have been repaired or modified in such a manner as to damage them;
- (b) any products that, in the Company's judgement, have been exposed to negligence or adverse conditions or stored improperly;
- (c) any products that were not operated or serviced in accordance with normal practice and with the recommendations and specifications issued by the Company;
- (d) broken warranty seals, if any, will immediately void the warranty.

The Manufacturer's obligations under this warranty are limited to using reasonable efforts to repair, or alternatively, replace during regular working hours those products that in the Manufacturer's judgement proved not be as warranted within the applicable warranty period.

All costs of transportation of any claimed, repaired or replaced products to or from the Company's facility shall be borne by the Purchaser.

The Company may demand that the claimed product be delivered to its facility at the Purchaser's expense in order to establish whether the claim is covered by warranty.

The installation costs for a repaired or replacement product shall be borne by the Purchaser. Replacement parts provided under this warranty are covered for the remainder of the warranty period as if they were original equipment parts. This warranty does not cover downtime; the Company disclaims all liabilities for damages caused by any delays in connection with warranty service.

PLEASE READ THIS DOCUMENT CAREFULLY

Please read the entire document carefully before installing, commissioning, operating, servicing or disposing of the equipment.

SAFETY INFORMATION

Use great care when working with this equipment. It is normally used in connection with or connected to circuits operating at dangerous voltage levels and can be fatal.

The following section contains important information on the safety rules that must be observed when installing and operating the equipment.

Improper use of the equipment or lack of care in applying the safety procedures and instructions provided in this document may create a hazard. Avoid contact with voltage or current sources.

Do not remove the protections or safety devices for any reason whatsoever.

SERVICING THE EQUIPMENT - SKILLS

Servicing and access to the internal parts of the equipment shall be done by qualified, properly trained personnel aware of the risks associated with electricity and high voltage.

Follow the safety rules when using the equipment or cables and other apparatus connected to it.

Issue 03/09/2019

Suspended edition 05/11/2018

LETG - LED ELEVATED RUNWAY GUARD LIGHT

DO NOT WORK ON LIVE CIRCUITS

Do not work on the converter or any apparatus connected to it when the circuits are live.

WHEN USING AND MAINTAINING THE EQUIPMENT, OBSERVE THE PRECAUTIONS FOR HIGH VOLTAGE

Before each access, inspection or operation, ensure that the equipment has been switched off by opening the main switch and removing power to the units (open power switch upstream of line).

Wait until discharge time has elapsed (at least 5 minutes) and check for voltage before accessing the equipment.

RESUSCITATION

Maintenance personnel must be aware of the risks connected with electricity and the criteria for the prevention of electrical shock hazards and should be familiar with resuscitation techniques.

CE MARK

This equipment complies with the requirements of European regulations on CE marking. User must observe all instructions provided in this document.

This equipment complies with the requirements of EEC Directives 2004/108/EEC and 2006/95/EEC concerning "Electromagnetic Compatibility" and "Low Voltage Electrical Equipment", respectively

TAKING THE EQUIPMENT OUT OF SERVICE

In the event of scrapping, dismantling, destruction or disposal, user must observe all necessary precautions for the components and materials to be disposed of, in accordance with local regulations and applicable law in force.

1 GENERAL INFORMATION

LETG is an LED Elevated Runway Guard Light with two yellow lights that flash alternately. It is used to warn pilots or ground vehicle operators that they are approaching the runway.

LETG is in compliance with:

- **ICAO** – Annex 14, Vol.I, Sect.5.3.23 Configuration A, high intensity
- **FAA** – AC 150/5345-46 and Engineering Brief No.67, meets the requirements outlined in AC 150/5340-30
- **EASA** – CS-ADR-DSN Book 1 Fig.U-28
- **IEC** – TS 61827
- **NATO** – STANAG 3316
- **CAA** – CAP 168
- **IAAE** – TP 312
- **ENAC** – Regulation on airport construction and operations of the Italian Civil Aviation Authority

2 KEY FEATURES

2.1 Description of LETG light fixture

The fixture consists of:

- Two unidirectional yellow LED light sources spaced 381 mm (15") apart. The two light sources flash alternatively at a rate of 45-50 times per minute.
- Aluminium housing accommodates LED boards and power supply unit.
- U-shaped aluminium support frame with zenith and azimuth angle adjustment marks. Zenith angle can be adjusted in a 0° to 20° range in 1° increments. Azimuth angle can be adjusted in a -20° to +20° range in 5° increments.
- Mounting leg with frangible groove and 2"-11 ½ NPT male threading
- L-823 power connector, 2-pin without monitoring or 5-pin with monitoring.
- Use a control and monitoring device capable of detecting a single burnt-out lamp (MCC)
- The fixture will be installed on a high-strength steel base plate with 2"-11 ½ NPSM threading

2.2 Input power

Two versions are available with the following characteristics:

- powered by 2.8A - 6.6A series circuit (FAA Mode 1)
- voltage driven 120Vac-240Vac (FAA Mode 2)

LETG - LED ELEVATED RUNWAY GUARD LIGHT

MODE	CONSUMPTION	TRANSFORMER	CCR
1. Series circuit	32VA	45W	65VA
1. Series circuit (config. E)*	32VA *	45W *	65VA *
2. 120V parallel circuit	32VA	-	-
2. 240V parallel circuit	32VA	-	-

Table 1 – Consumption

*Note: The consumption refers to a single light source on. If both the light source are on, the consumption become double.



NOTE: Electrical characteristics have been determined using current regulators and insulation transformers manufactured and/or marketed by OCEM. These data may vary when third-party current regulators and transformers are used.

2.3 Operating conditions

- Operating temperature -55°C to +55°C (-40°F to +131°F)
- Humidity: 0 to 100%
- Wind velocity: 483 km/h (300mph)

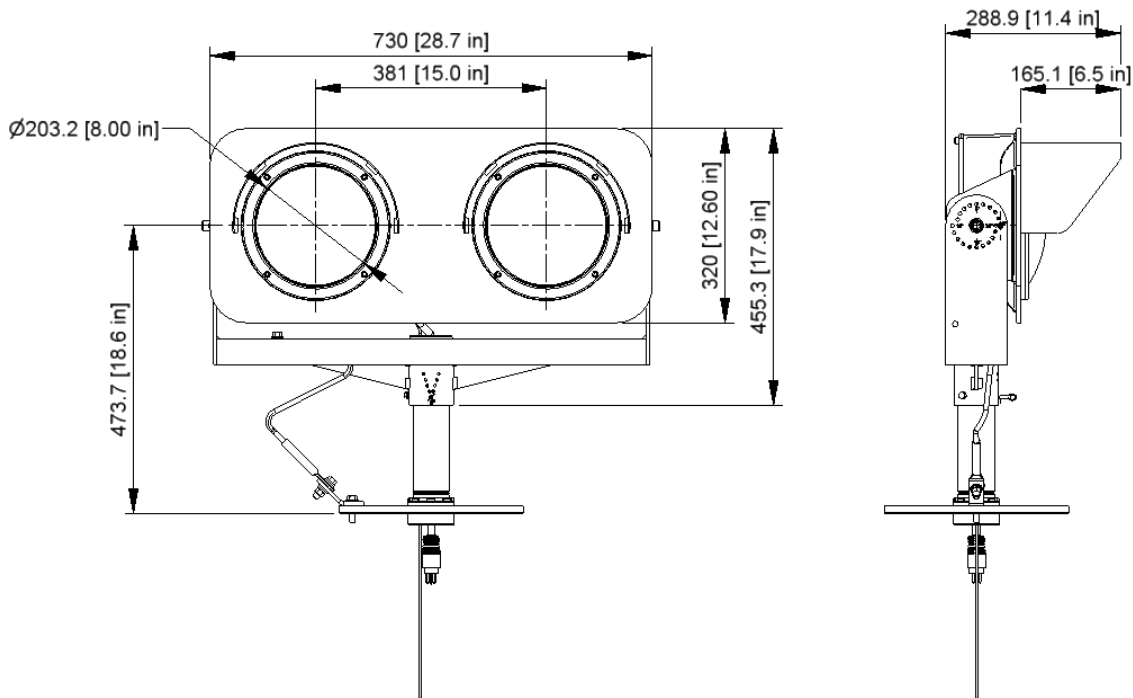

Figure 1 - Overall dimensions

WEIGHT	OUTER PACKING
18kg	80x50x35 cm

Table 2 - Weight and Volume of LETG

Issue 03/09/2019

Suspended edition 05/11/2018

LETG - LED ELEVATED RUNWAY GUARD LIGHT

3 FIXTURE TYPE IDENTIFICATION

LETG - I - S - M - 0 - 0 - T**Basic P/N****Conformity**

IY = ICAO Yellow

FY = FAA Yellow

TR = Traffic Red

Mode of operation

S= Series Power Circuit

D= 120V to 240V Parallel Power Circuit

Monitoring

0= Non-monitored

M= Monitored

Photocell (mode of operation D only)

F= With Photocell

0=No Photocell

Power disconnection

C = ON/OFF Switch (standard on FY version)

0= No ON/OFF Switch

Options (list all selected options)

T = Safety Rod (standard on FY version)

E = External Synchronization with double cable lead power supply

L = Low Installation Profile (height = 360 mm)

Figure 2 - P/N explanation

4 INSTALLATION

The fixture is normally installed on level ground, at the edges of the runway, on a 12" FAA L-867 base, that will be used to house the transformer, and a base plate. Please refer to FAA instructions provided in AC 150/5340-30 and ICAO Annex 14, vol. I.

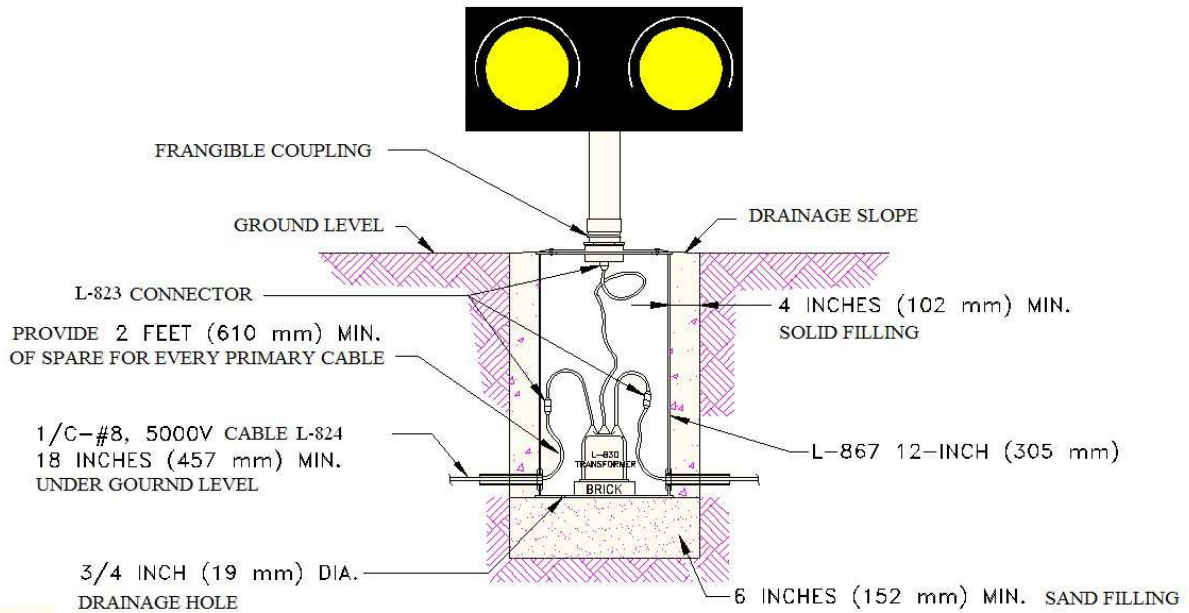

Figure 3 - Installation on FAA L-867 base plate and base plate

Assuming that the L-867 base has been correctly installed, install fixture and base plate (fig.3) as follows:

- Thread the fixture connector through U-shaped frame, frangible coupling and locking ring; ensure to screw the locking ring all the way up to the edge of frangible coupling thread.
- Connect fixture connector to the receptacle in the top section of the base plate
- Screw the frangible coupling onto the threaded section of the base plate. Apply anti-seize grease first and do not tighten yet.
- Orient the row of holes in the frangible coupling in the same direction as the light beam (horizontally) and tighten the locking ring fully onto the base plate.
- Insert the fixture with the U-shaped frame on the frangible coupling and insert the alignment pin through the holes. Do not tighten the two rear retaining screws of the U-shaped support frame.
- Orient the fixture (see section 5).
- Tighten the two screws at the rear of the U-shaped support frame on the frangible coupling.

LETG - LED ELEVATED RUNWAY GUARD LIGHT

- Connect the tether to the base of the LETG U-shaped support frame from the side opposite to the runway; connect the other end to the base plate.
- Tighten all components on base plate, support frame and fixture

4.1 External synchronization with double lead power supply

The light fixture with the external synchronization (option E) should be mechanically installed as described above.

The only difference is the presence of two independent cable leads for power supply, one for each light source.

The device for the external synchronization, not included with the light fixture, switches the power supply between the two cable leads, feeding the two light source.

4.2 Low Installation Profile

The low installation profile (option L) allows the installation of the light fixture at 360mm height. Install the fixture as follows:

- Thread the fixture connector through U-shaped frame;
- Connect the fixture connector to the receptacle;
- Fix the U-shaped frame to the ground through the proper hole in the L-profile;

NOTE: the azimuthal orientation is fixed at the time of installation and can not be modified retrospectively.

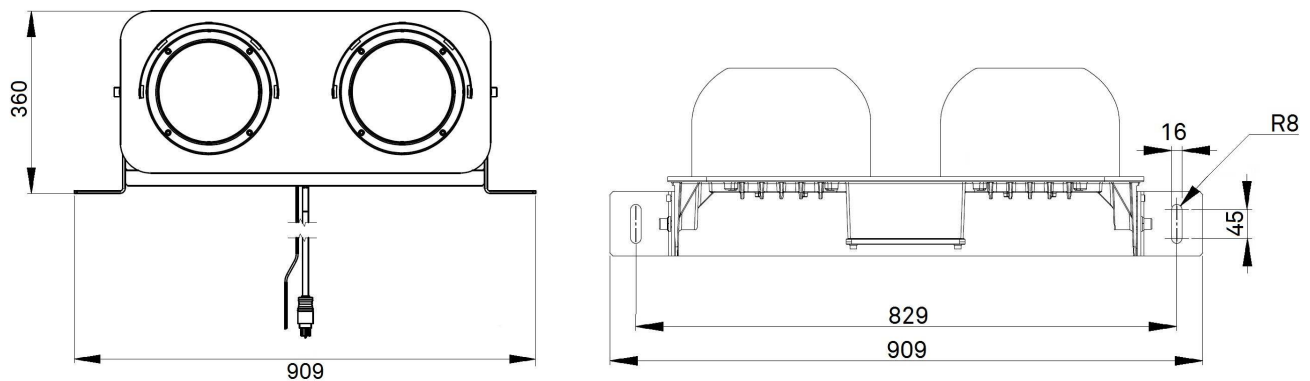

Figure 4 – LETG installation in low installation profile.

5 AZIMUTH AND ZENITH ANGLE ADJUSTMENT

LETG must be oriented so as to maximise the visibility of the light to pilots approaching the stop line before the take-off runway. Generally, the orientation should be specified by the design engineer so that the centre of the light beam will be aimed to the cockpit when the aircraft is 45 to 60 metres away from the stop line, along the predominant taxi path to the stop line. The vertical aiming angle must be set between 5 and 10 degrees above the horizon. The design engineer must specify the aiming of the light so to provide a steady light intensity of at least 300 candle power at the highest intensity step when viewed from all angles between 45 and 60

LETG - LED ELEVATED RUNWAY GUARD LIGHT

metres from the stop line. If these criteria cannot be met for all taxi paths to the stop line, consider using multiple LETGs oriented in such a manner to cover all different paths and in-pavement light fixtures to increase coverage, or orienting the individual fixtures at both sides of the stop line so as to achieve optimal lighting of the predominant taxi path.

To set light aiming, follow these steps and refer to fig. 4:

1. Position the horizontal aiming pin in the appropriate hole of the horizontal aiming index.
2. Tighten the two ½” screws that secure the support frame to the frangible coupling.
3. Align the vertical aiming index hole of the U-shaped support frame with the appropriate aiming index hole of the fixture housing.
4. Lock in place using one M6 screw on each side.
5. Tighten the two M12 screws on the sides to secure housing to support frame.
6. Tighten all screws.

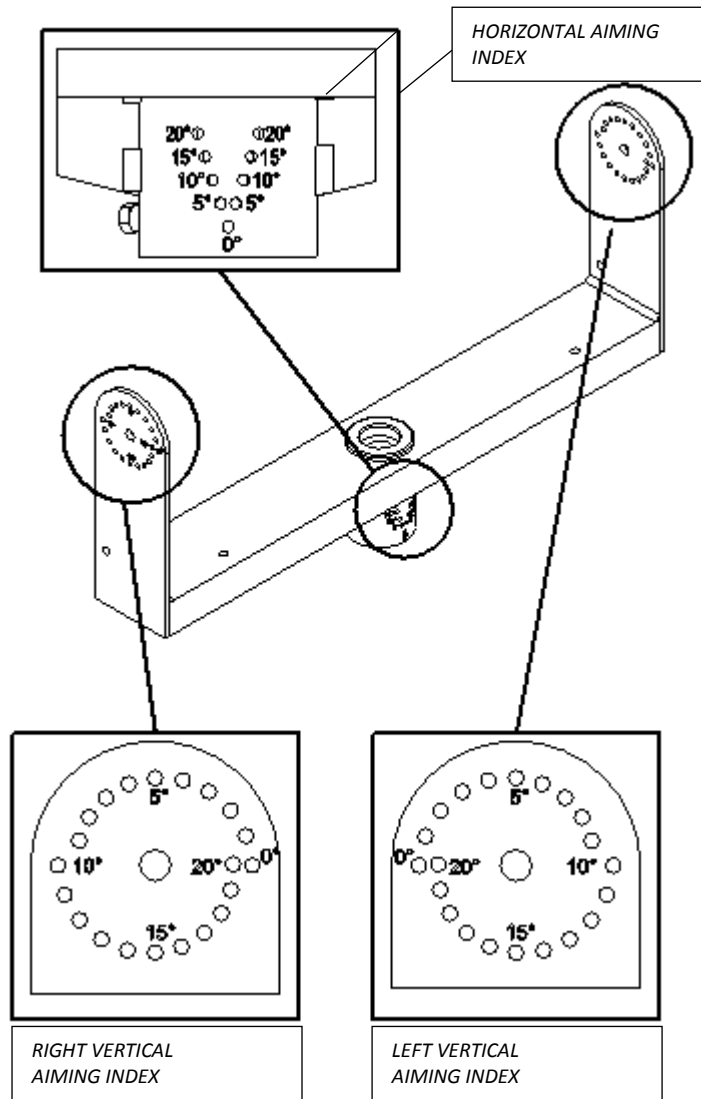

Figure 5 - Horizontal and vertical aiming indexes

6 MAINTENANCE

WARNING!

Never work on electrical and electronic equipment when the CCR is powered on.

NOTE

ALL MAINTENANCE SHOULD BE PERFORMED BY QUALIFIED PERSONNEL ONLY.

The basic purpose of a visual aid system is to ensure safe aircraft operations. This is why they need to be maintained to stringent standards.

Once the system has been installed, it will serve its purpose effectively only if maintained in good working order through effective maintenance.

6.1 Periodic checks

Routine inspection, cleaning and maintenance intervals vary according to type, location and use of the equipment.

A maintenance schedule targeted to required service standards should be prepared for each airport based on past experience

The guidelines for a preventive maintenance plan are outlined below.

DAILY CHECKS	1) LEDs not lighting
	2) Damaged fixture parts
	3) Flashing
MONTHLY CHECKS	1) Lens cleanliness
	2) Proper setup of fixture
EVERY SIX MONTHS	1) Paint or replace parts showing corrosion
YEARLY CHECKS	1) Stability of civil engineering works
	2) Stability and assembly of fixtures
	3) Electrical components and connections; degree of insulation
	4) Lighting efficiency of LEDs
	5) Condition of all gaskets

Table 3 -Periodic checks

6.2 Non-scheduled maintenance

Inspect fixtures after any abnormal weather events, and remove any debris obstructing the light beam.

6.3 REPLACEMENT

WARNING!
ENSURE THAT POWER HAS BEEN REMOVED BEFORE REPLACING ANY COMPONENTS.
DO NOT WORK ON LIVE PARTS!!!

NOTE
ALL MAINTENANCE SHOULD BE PERFORMED BY QUALIFIED PERSONNEL ONLY.

6.3.1 Replacing lens and gasket

1. Unscrew the four screws of the locking ring that hold the lens in place and remove the lens
2. Remove the damaged lens and inspect its gasket
3. Replace the damaged lens and its gasket as required
4. Tighten the four screws to secure the locking ring

6.3.2 Replacing the LED board

1. Unscrew the four screws of the rear panel
2. Disconnect the two cables from connector J1 of board F266
3. At the front end, unscrew the four screws of the locking ring, the locking ring, the lens, the gasket and the screen
4. Unscrew the four screws securing the LED board and peel the heat-conducting film off the fixture housing
5. Replace the damaged LED board by reversing the above procedure

6.3.3 Replacing the power supply board (power supply board assembly)

1. Unscrew the four screws of the rear panel
2. Disconnect the power terminals of LEDs and monitoring device (if fitted), the dusk sensor terminal and the fast-on terminals of the input power supply cables.
3. Unscrew the four screws securing the support to the power supply board assembly and the eyelet terminal with earth cable.
4. Replace the support with the power supply board assembly by reversing the above procedure

Note: The configuration with the external synchronization (option E) have two power supply boards, one for each light source; identify the faulty power supply board and replace it as described above.

6.3.4 Replacing the power supply cable with connector

1. Unscrew the four screws of the rear panel
2. Disconnect the power supply fast-on terminals, the terminal of the monitoring device (if fitted) and unscrew the screw to which the earth cable with eyelet terminal is connected
3. Unscrew the outer nut of the cable gland that holds the power supply cable with connector in place
4. Withdraw the power supply cable with connector and replace with a new one
5. Reverse the above procedure

Note: The configuration with the external synchronization (option E) have two power supply cables, one for each light source; identify the faulty power supply cable and replace it as described above.

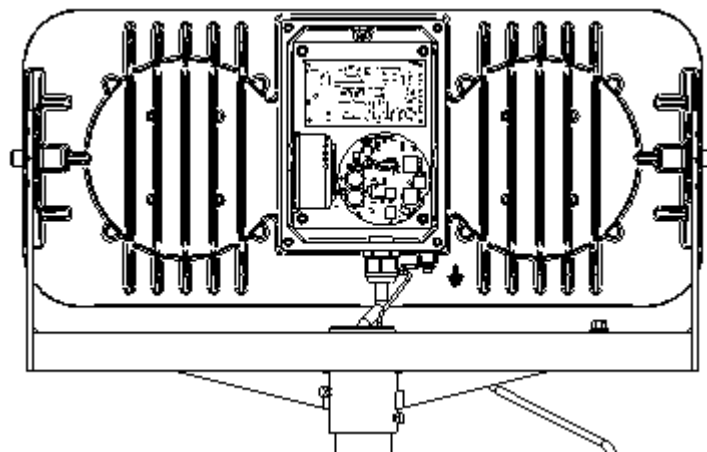

Figure 6 - Series power supply unit housing

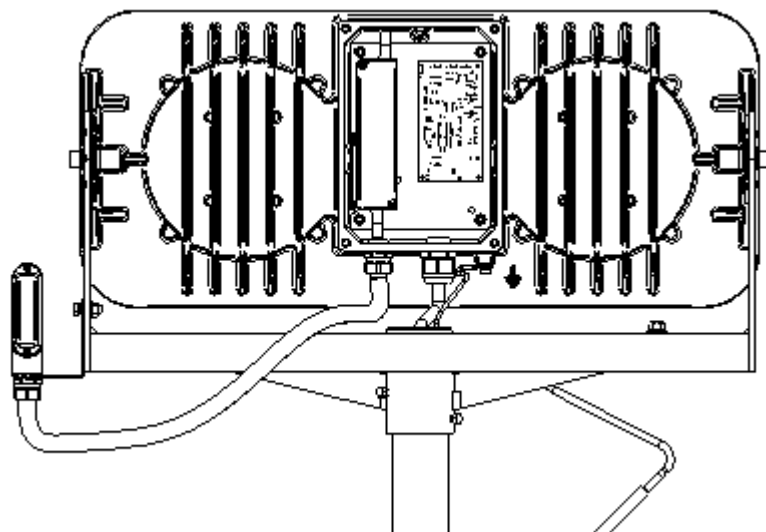

Figure 7 - Housing of parallel power supply unit with dusk sensor

7 TROUBLESHOOTING

PROBLEM	POSSIBLE CAUSE	CORRECTIVE ACTION
Both light sources not lighting	Faulty LED board	Replace board
	Faulty power supply unit	Replace power supply unit
	Incorrect input power	For series circuit - Check to ensure that RMS current is between 2.8 and 6.6 A using an amperemeter
		For parallel circuit - Check for proper 100-240Vac voltage
	Power supply cables of board damaged	Replace damaged cables
	Monitoring relay tripped	Replace LED board and displace relay lever to enable power
Light sources flashing irregularly	Faulty power supply unit	Replace power supply unit
Input board not powered	Faulty insulation transformer	Replace insulation transformer in L-867 base

Table 4 - Troubleshooting

LETG - LED ELEVATED RUNWAY GUARD LIGHT

8 WIRING DIAGRAMS

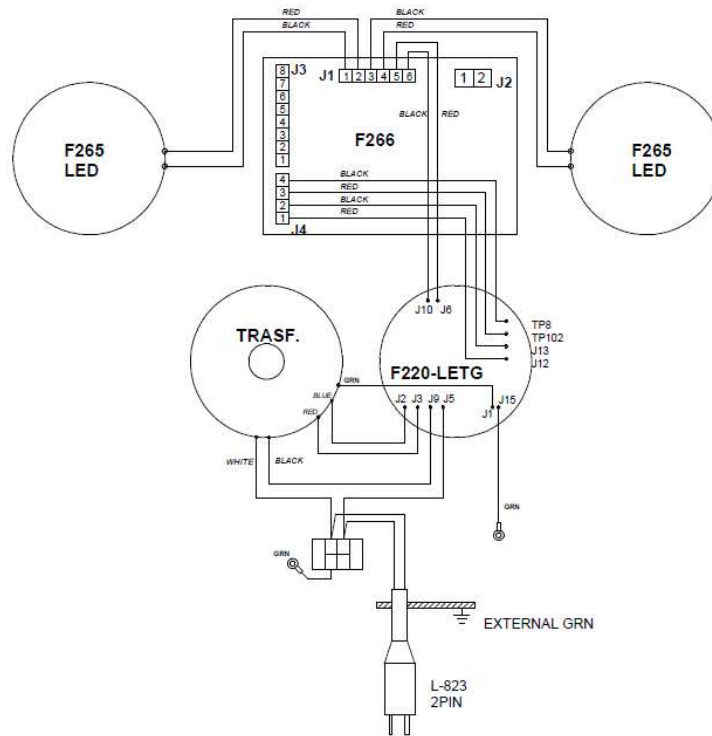

Figure 8– Non-monitored series circuit power supply

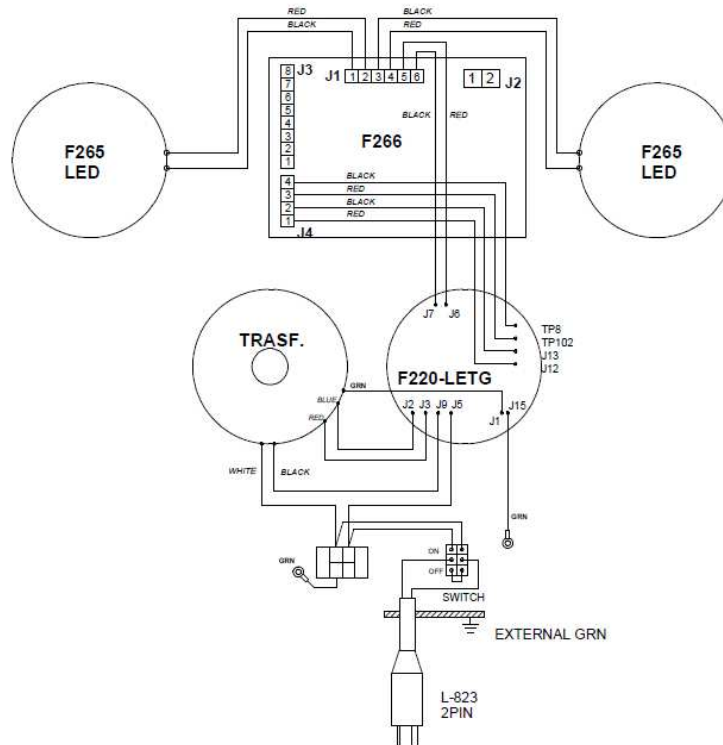

Figure 9– Non-monitored series circuit power supply with switch

LETG - LED ELEVATED RUNWAY GUARD LIGHT

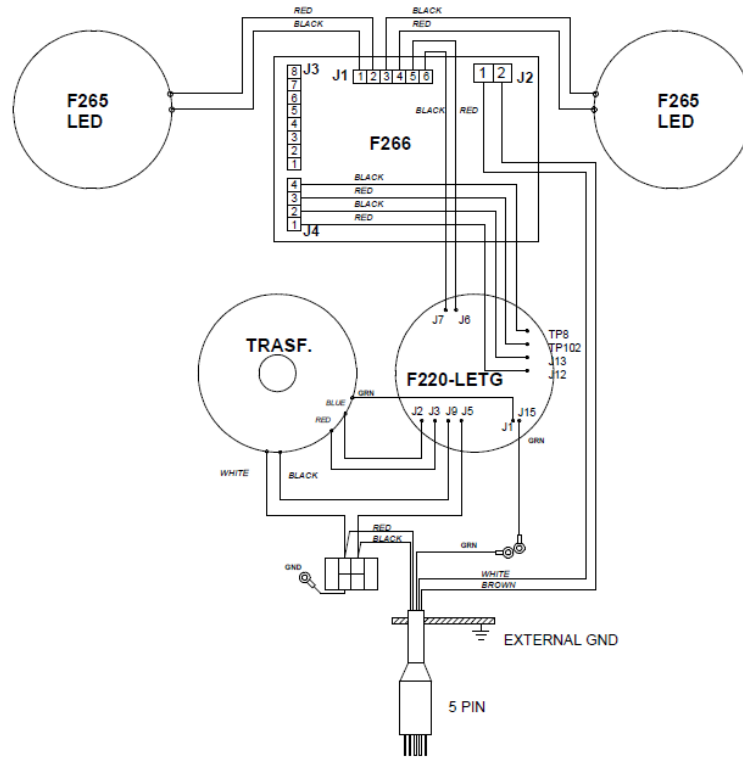

Figure 10– Monitored series circuit power supply

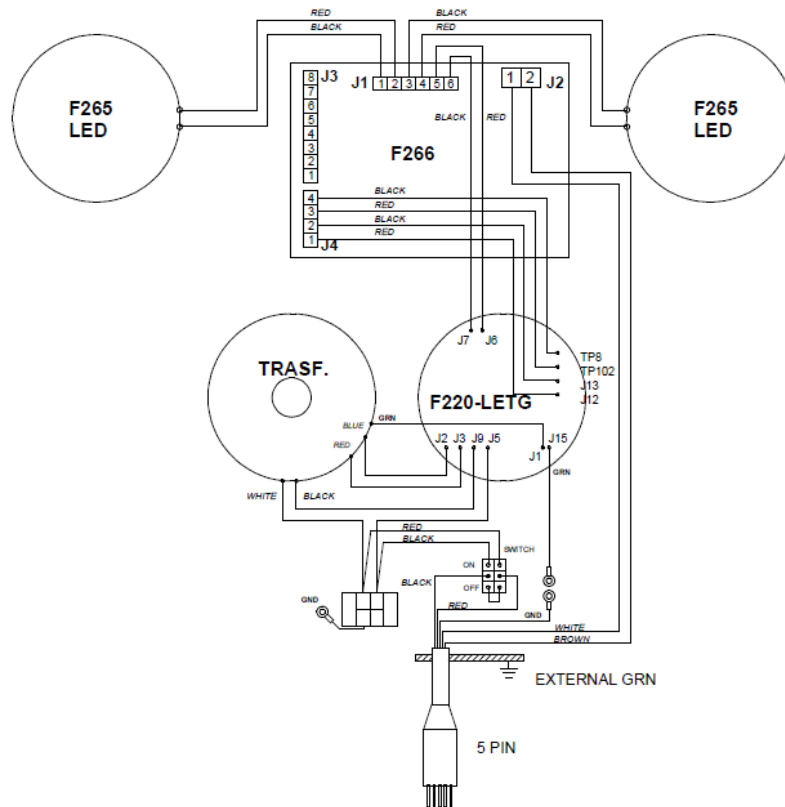

Figure 11– Monitored series circuit power supply with switch

LETG - LED ELEVATED RUNWAY GUARD LIGHT

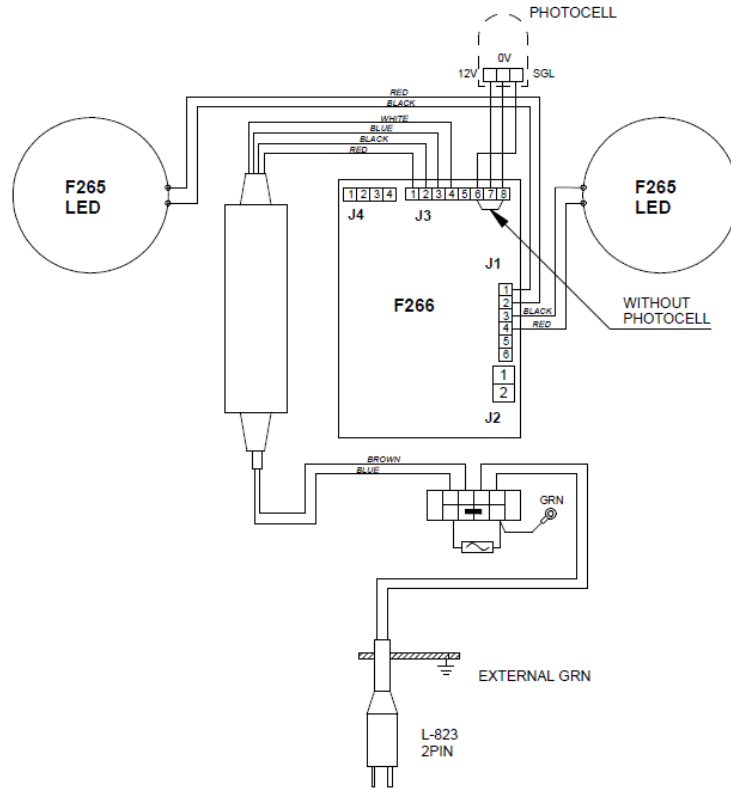

Figure 12– Non-monitored parallel circuit power supply with or without photocell

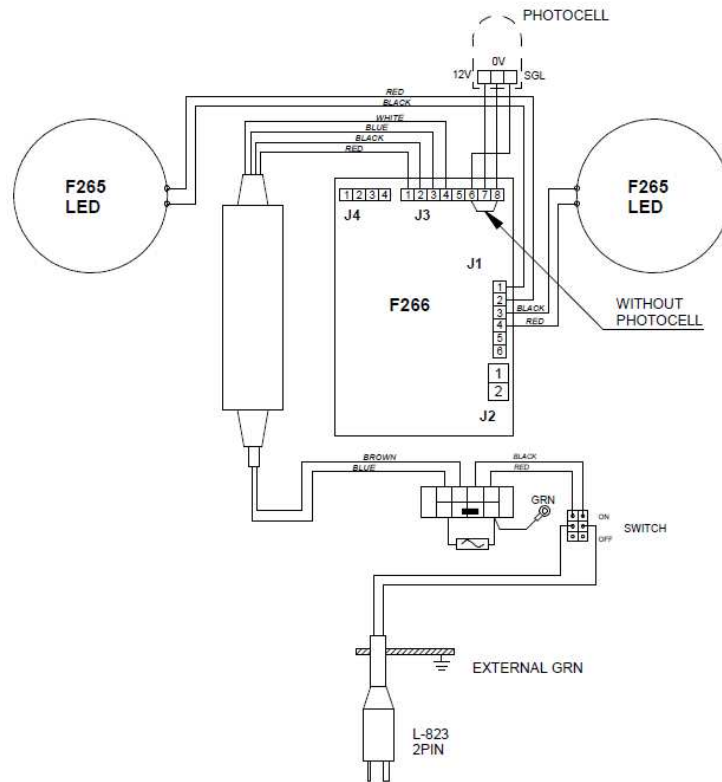

Figure 13– Non-monitored parallel circuit power supply with switch, with or without photocell

LETG - LED ELEVATED RUNWAY GUARD LIGHT

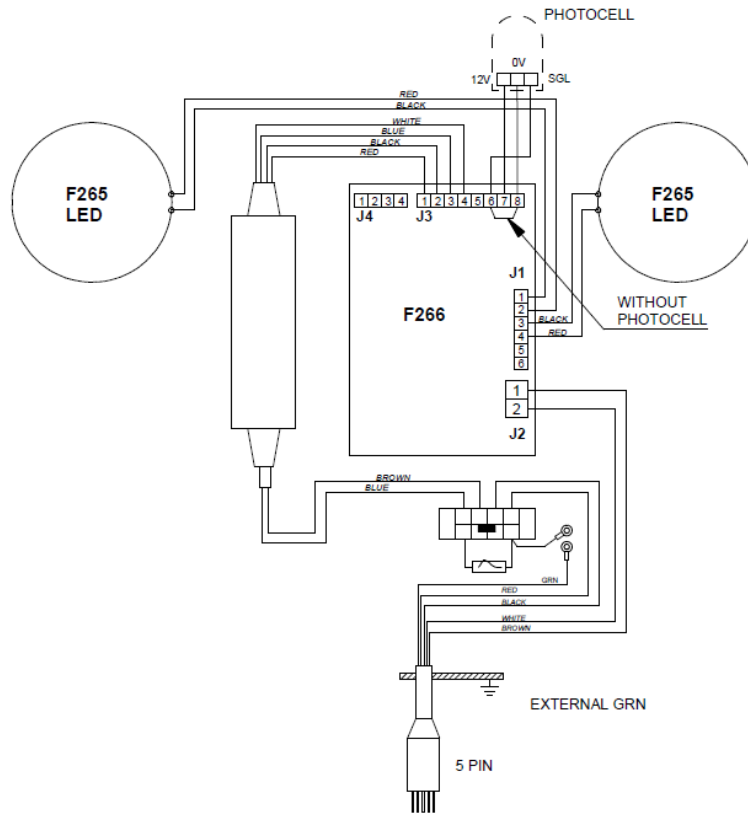

Figure 14– Monitored parallel circuit power supply with or without photocell

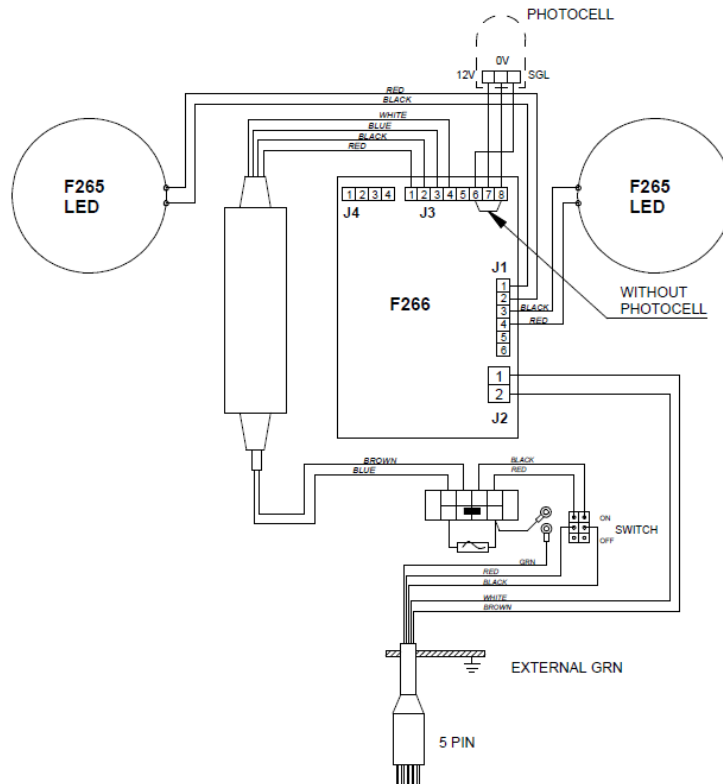

Figure 15– Monitored parallel circuit power supply with switch, with or without photocell

LETG - LED ELEVATED RUNWAY GUARD LIGHT

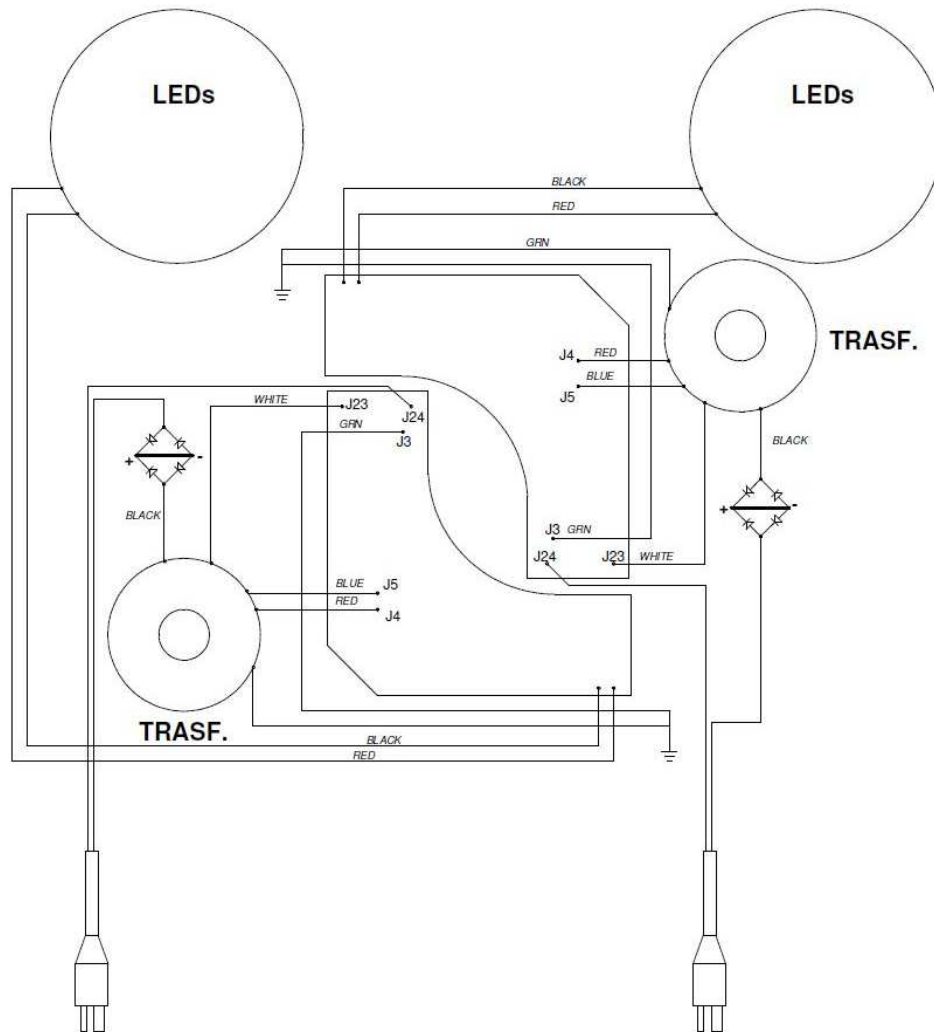

Figure 16 - Non-monitored series circuit power supply with external synchronization

LETG - LED ELEVATED RUNWAY GUARD LIGHT

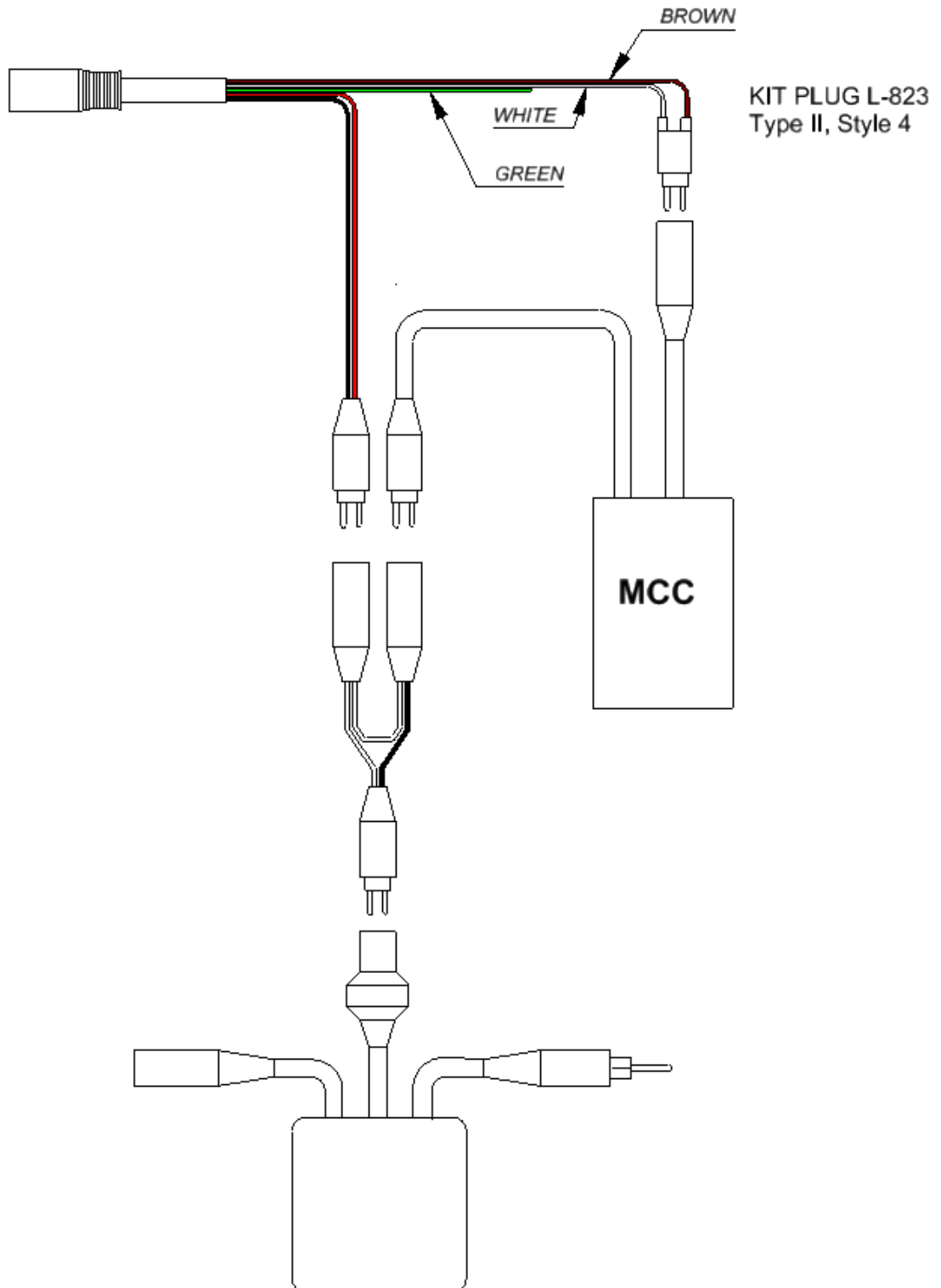

Figure 17 – Wiring diagram for connection of monitored LETG to transformer.

9 SPARE PARTS

CODE	DESCRIPTION
RISLB0001	Kit lens with gasket
RISLB0002	LED Module F265, 14 LEDs YELLOW
RISLB0003	Non-Monitored series circuit power supply board assembly
RISLB0004	Monitored series circuit power supply board assembly
RISLB0005	Non-Monitored parallel circuit power supply board assembly
RISLB0006	Monitored parallel circuit power supply board assembly
RISLB0007	Non-monitored series circuit power supply board with external synchronization
RISLB0008	Kit Breakable coupling
RISLB0009	Cable lead with plug FAA L-823, L=1m
RISLB0010	Cable lead with five-pole plug for monitored fixture
RISLB0011	Kit photocell (only for Operating mode D)
RISLB0012	LETG door gasket