

T30 Fold-Over Tower

Assembly and Installation Manual

**February
2013**

Approach Navigation Systems Inc
667 Malenfant Blvd.
Dieppe, New Brunswick, Canada E1A 5T8
Tel.: (506) 854-2967
FAX: (506) 854-0030
URL: www.approachnavigation.com



Table of Contents

Table of Contents _____	2
GENERAL INFORMATION _____	3
PURPOSE	3
GENERAL DESCRIPTION	3
TECHNICAL SPECIFICATIONS – Design Specifications _____	4
MAXIMUM ALLOWABLE AVERAGE WIND VELOCITY TABLES _____	5
FOUNDATION SPECIFICATIONS _____	11
TOWER ASSEMBLY _____	12
GENERAL TOWER ASSEMBLY	12
RECOMMENDED ANCHOR BOLT TORQUE _____	18
TOWER MAINTENANCE _____	18
APPENDIX A _____	19
PARTS LIST - DRAWING	19
PARTS LIST	20
TOWER FOLDED AND UPRIGHT	21

GENERAL INFORMATION

PURPOSE

ANS Inc offers the **T30 FOLD-OVER TOWER**, purpose-designed to mount atmospheric instruments, cameras, antennae and other equipment, primarily for aviation and roadway weather observation use. The winched folding feature permits easy maintenance of mounted components by a single technician. Custom colors are available in a powder coat finish, for additional charge.

This document is intended to provide the necessary information to assemble the ANS T30 folding tower.

GENERAL DESCRIPTION

The tower consists of three, ten-foot triangular sections of corrosion resistant aluminum alloys. A stainless steel hinge and winch assembly is installed on the first two sections. The hardware for the tower is stainless steel, and bracket assemblies are of galvanized steel.

TECHNICAL SPECIFICATIONS – Design Specifications



CODES

International Building Code IBC 2009.

EIA/TIA-222-F & EIA/TIA-222-G.

CSA S37-01 "Antennas, Towers, and Antenna-Supporting Structures.

CSA S157-05 "Strength Design in Aluminum.

Purchaser checklist:

- It is the responsibility of the purchaser to verify that the wind loads and design criteria specified meet the requirements of the local building code.
- It is the responsibility of the purchaser to specify appropriate ice loads for locations where ice accumulation is known to occur.
- The basic wind speeds provided correspond to an annual probability of being exceeded of 0.02 (50 – year recurrence interval). Specific sites may have local extreme wind conditions. Topographical characteristics such as smooth terrain, bluffs, ducting, mountain top exposure, and prevailing wind directions can significantly increase wind speeds. It is the responsibility of the purchaser to consult local information sources to confirm applicable basic wind velocity to be considered at the installation site.
- When the standard foundations and anchors are utilized for the installation of the tower, it is the purchaser's responsibility to verify by geotechnical investigation that actual site conditions equal or exceed the soil parameters listed on the drawing. Also, by choosing to utilize the standard foundations, the purchaser accepts the responsibility and liability for the adequacy of the subsurface soil conditions.
- It is the responsibility of the purchaser to verify that the depths of standard foundations are adequate based on the frost penetration and/or the zone of seasonal moisture variation.



Approach Navigation Systems Inc.

667 Malenfant Blvd.
Dieppe, New Brunswick TEL: 506 854-2967
Cahadd E1A 5T8 FAX: 506 854-0030

PROJECT TITLE:

ANS TOWER T3000

DRAWING TITLE:

General Arrangement

SCALE:

NTS

DRAWN BY:

DATE:

Aug. 8, 2012

SHEET NUMBER:

DRAWING NUMBER:

REV:

The information contained herein is proprietary to Approach Navigation Systems Inc and is used solely for the purpose for which it is supplied. It shall not be disclosed in whole or in part to any other party without the express permission in writing by Approach Navigation Systems Inc.

MAXIMUM ALLOWABLE AVERAGE WIND VELOCITY TABLES

TABLE 1 – No Ice on Tower

TOWER TYPE T3000 – BASIC WIND VELOCITIES					
Material:		Legs - Extruded Aluminum Alloy 6061-T6, Lattice - Aluminum Tube Alloy 6061-T4,		thickness = 7.85 mm diameter = 19.1 mm Thickness = 1.65 mm	
Maximum basic wind velocity on tower (MPH)					
Height of Appurtenance from base of tower	Appurtenance (antenna)				
	No Antenna	1.5 ft ²	3.0 ft ²	6.0 ft ²	9.0 ft ²
10'-0"	91	90	88	86	83
20'-0"	91	88	85	81	76
30'-0"	91	87	83	76	71
Applicable wind velocity reduction to compensate for Installation of each appurtenance on tower (MPH)					
Height of Appurtenance from base of tower	Appurtenance (antenna)				
	No Antenna	1.5 ft ²	3.0 ft ²	6.0 ft ²	9.0 ft ²
10'-0"	----	-1	-3	-5	-8
20'-0"	----	-3	-6	-10	-15
30'-0"	----	-4	-8	-15	-20

TABLE 2 – ½" Ice on Tower

TOWER TYPE T3000 – BASIC WIND VELOCITIES					
Material:	Legs - Extruded Aluminum Alloy 6061-T6,	thickness = 7.85 mm			
	Lattice - Aluminum Tube Alloy 6061-T4,	diameter = 19.1 mm			
		Thickness = 1.65 mm			
Maximum basic wind velocity on tower (MPH)					
Height of Appurtenance from base of tower	Appurtenance (antenna)				
	No Antenna	1.5 ft ²	3.0 ft ²	6.0 ft ²	9.0 ft ²
10'-0"	88	87	86	84	82
20'-0"	88	86	84	81	78
30'-0"	88	85	82	77	73
Applicable wind velocity reduction to compensate for Installation of each appurtenance on tower (MPH)					
Height of Appurtenance from base of tower	Appurtenance (antenna)				
	No Antenna	1.5 ft ²	3.0 ft ²	6.0 ft ²	9.0 ft ²
10'-0"	----	-1	-2	-4	-6
20'-0"	----	-2	-4	-7	-10
30'-0"	----	-3	-6	-11	-15

TABLE 3 – ¼" Ice on Tower

TOWER TYPE T3000 – BASIC WIND VELOCITIES					
Material:		Legs - Extruded Aluminum Alloy 6061-T6, Lattice - Aluminum Tube Alloy 6061-T4,		thickness = 7.85 mm diameter = 19.1 mm Thickness = 1.65 mm	
Maximum basic wind velocity on tower (MPH)					
Height of Appurtenance from base of tower	Appurtenance (antenna)				
	No Antenna	1.5 ft ²	3.0 ft ²	6.0 ft ²	9.0 ft ²
10'-0"	80	80	79	77	76
20'-0"	80	79	77	75	72
30'-0"	80	78	76	72	69
Applicable wind velocity reduction to compensate for Installation of each appurtenance on tower (MPH)					
Height of Appurtenance from base of tower	Appurtenance (antenna)				
	No Antenna	1.5 ft ²	3.0 ft ²	6.0 ft ²	9.0 ft ²
10'-0"	----	Nil	-1	-3	-4
20'-0"	----	-1	-3	-5	-6
30'-0"	----	-2	-4	-8	-11

TABLE 4 – 1” Ice on Tower

TOWER TYPE T3000 – BASIC WIND VELOCITIES					
Material:	Legs - Extruded Aluminum Alloy 6061-T6,		thickness = 7.85 mm		
	Lattice - Aluminum Tube Alloy 6061-T4,		diameter = 19.1 mm		
			Thickness = 1.65 mm		
Maximum basic wind velocity on tower (MPH)					
Height of Appurtenance from base of tower	Appurtenance (antenna)				
	No Antenna	1.5 ft ²	3.0 ft ²	6.0 ft ²	9.0 ft ²
10'-0"	73	73	72	71	69
20'-0"	73	72	71	67	64
30'-0"	73	71	69	64	60
Applicable wind velocity reduction to compensate for Installation of each appurtenance on tower (MPH)					
Height of Appurtenance from base of tower	Appurtenance (antenna)				
	No Antenna	1.5 ft ²	3.0 ft ²	6.0 ft ²	9.0 ft ²
10'-0"	----	Nil	-1	-2	-4
20'-0"	----	-1	-2	-6	-9
30'-0"	----	-2	-4	-9	-13

TABLE 5 – 1 ¼" Ice on Tower

TOWER TYPE T3000 – BASIC WIND VELOCITIES					
Material:	Legs - Extruded Aluminum Alloy 6061-T6, Lattice - Aluminum Tube Alloy 6061-T4,	thickness = 7.85 mm diameter = 19.1 mm Thickness = 1.65 mm			
Maximum basic wind velocity on tower (MPH)					
Height of Appurtenance from base of tower	Appurtenance (antenna)				
	No Antenna	1.5 ft ²	3.0 ft ²	6.0 ft ²	9.0 ft ²
10'-0"	70	69	68	67	66
20'-0"	70	68	67	64	61
30'-0"	70	67	65	61	57
Applicable wind velocity reduction to compensate for Installation of each appurtenance on tower (MPH)					
Height of Appurtenance from base of tower	Appurtenance (antenna)				
	No Antenna	1.5 ft ²	3.0 ft ²	6.0 ft ²	9.0 ft ²
10'-0"	----	-1	-2	-3	-4
20'-0"	----	-2	-3	-6	-9
30'-0"	----	-3	-5	-9	-13

TABLE 6 – 2" Ice on Tower

TOWER TYPE T3000 – BASIC WIND VELOCITIES					
Material:		Legs - Extruded Aluminum Alloy 6061-T6, Lattice - Aluminum Tube Alloy 6061-T4,		thickness = 7.85 mm diameter = 19.1 mm Thickness = 1.65 mm	
Maximum basic wind velocity on tower (MPH)					
Height of Appurtenance from base of tower	Appurtenance (antenna)				
	No Antenna	1.5 ft ²	3.0 ft ²	6.0 ft ²	9.0 ft ²
10'-0"	64	63	62	61	60
20'-0"	64	62	61	59	57
30'-0"	64	62	60	56	53
Applicable wind velocity reduction to compensate for Installation of each appurtenance on tower (MPH)					
Height of Appurtenance from base of tower	Appurtenance (antenna)				
	No Antenna	1.5 ft ²	3.0 ft ²	6.0 ft ²	9.0 ft ²
10'-0"	----	-1	-2	-3	-4
20'-0"	----	-2	-3	-4	-6
30'-0"	----	-2	-4	-8	-11

TOWER ASSEMBLY

GENERAL TOWER ASSEMBLY

Refer to Appendix A for item list and drawings.

Note: These assembly instructions assume that the tower sections (item 4) are already assembled. When attaching parts/assemblies, flat washers are placed under the heads of bolts, with exception of carriage bolts, and behind all nuts. **Anti-seizing lubricant should be used on all bolts.**

Note: Due to the galvanizing process, the holes and slots may require cleaning with a 3/8" drill bit.

1. Attach the winch mounting bracket (item 14) to the bottom tower section on the tower leg (item 3) between the 3rd and 4th rung from the lower end of the tower section (item 4); the single elongated hole of the winch mounting bracket must be on the upper right. (Note all three tower sections are identical except that the bottom section has an ANS logo located on the bottom of one of the tower sections' legs.) Use 5/16" x 1 1/2" hex bolts and hardware (items 20, 21, 22) with the head of the bolt outside the tower leg. See Figure 1.
2. Attach the first 4" lever mounting bracket (item 8) at the 6th rung from the bottom, 2 rungs up from the winch bracket with 5/16" x 1 1/2" hex bolts and hardware (items 20, 21, 22). See Figure 1.

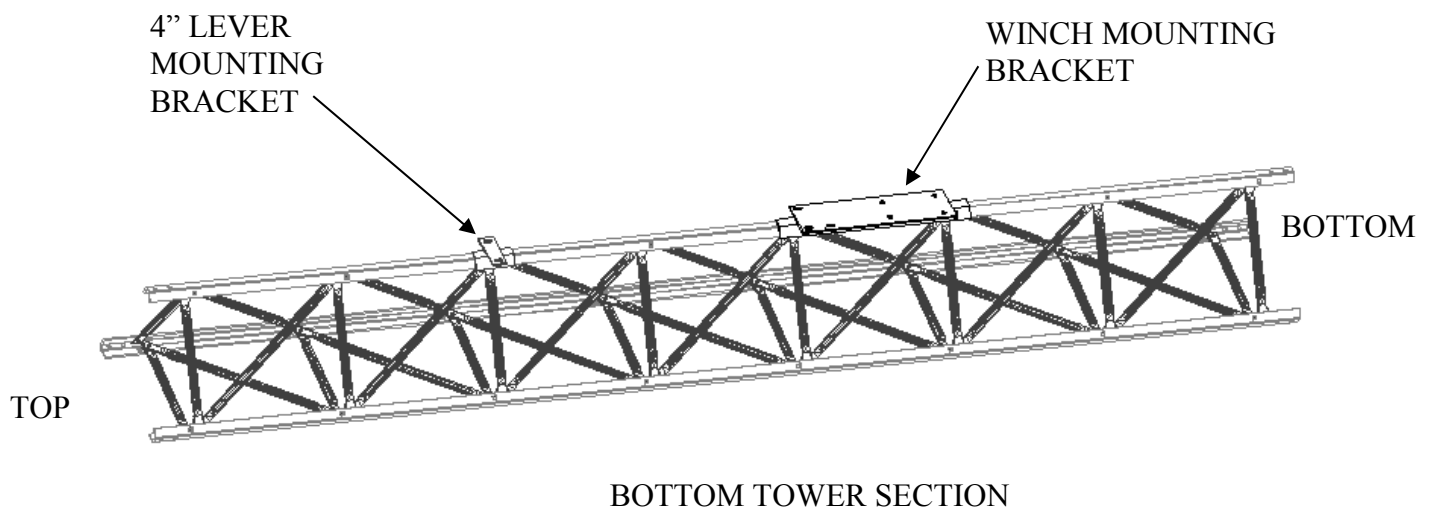

Figure 1 – Bottom Tower Section with Mounting Brackets Installed

- The winch plate (item 15) is attached to the middle pair of holes in the winch mounting bracket, by sandwiching the winch plate spacer (item 16) beneath and securing with $3/8'' \times 1 1/4''$ hex bolts and hardware (items 23, 24, 25). The portion of the winch plate (item 15) without holes should be downward, with the space beneath permitting the winch to slide into it securely. The winch is attached with its handle to the right with $3/8'' \times 1 1/4''$ hex bolts and hardware (items 23, 24, 25) through the bottom two holes. Read the instructions attached with the winch in order to complete its installation. See Figure 2.

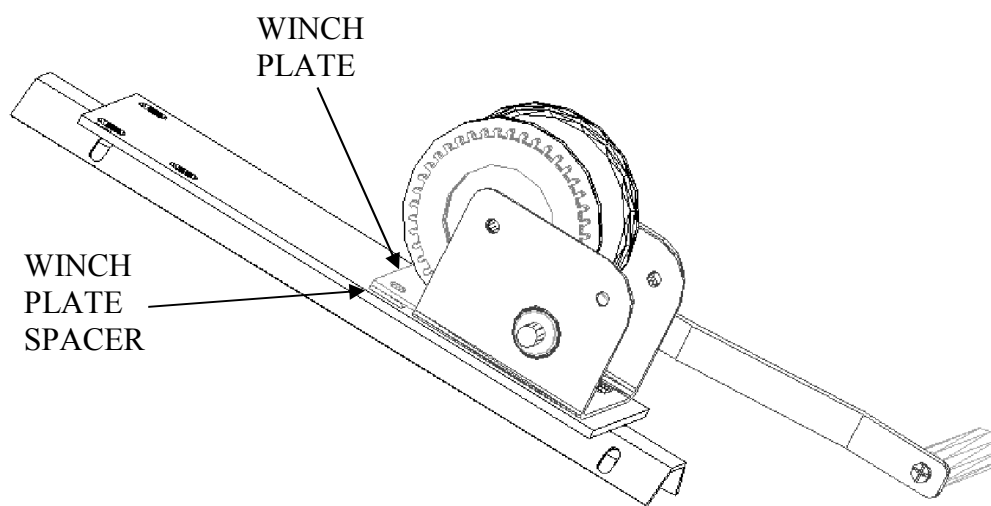

Figure 2 – Winch Mounted on Winch Plate Bracket

- Attach one of the hinge brackets (item 10) to the top of the bottom tower section (item 4) using the 3" hex spacer bars (item 6) and $7/16'' \times 2''$ hex bolts and hardware (items 26, 29, 30). Ensure that the holes on the hinge bracket for the hinge assembly are facing the top of the tower section and that these holes are on the opposite side of the tower leg that has the 4" mounting bracket and winch mounting bracket (items 8, 14). See Figure 3.

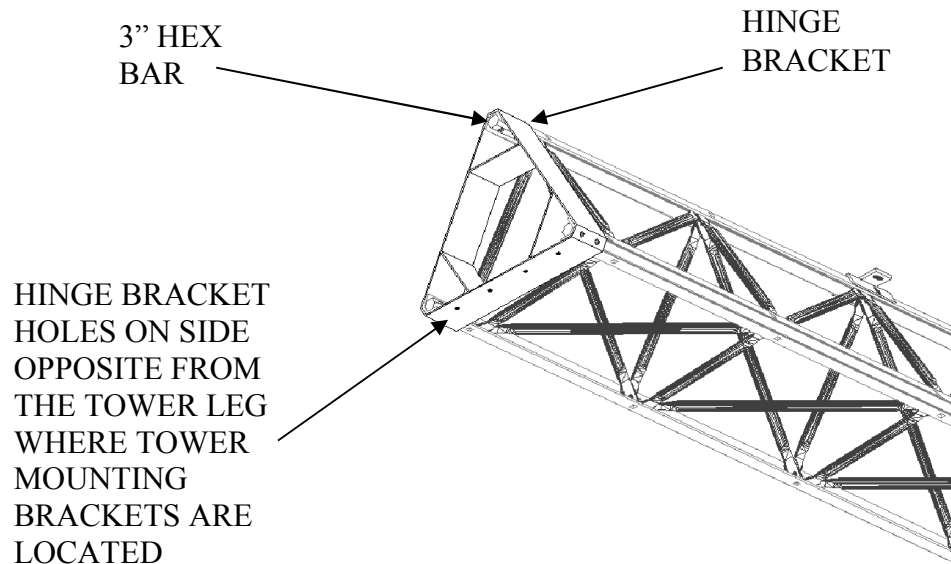

Figure 3 – Hinge Bracket Mounted with 3" Hex Bars

5. On the middle tower section (item 4), attach the 3" lever mounting bracket (item 7) on rung 1, and the 4" lever mounting bracket (item 8) at rung 3. Use 5/16" x 1 1/2" hex bolts and hardware (items 20, 21, 22) with the head of the bolt outside the tower leg. See Figure 4.

6. Attach a hinge bracket (item 10) to the bottom of the middle tower section (item 4) using the 3" hex spacer bars (item 6) and the 7/16" x 2" hex bolts and hardware (items 26, 29, 30). Ensure that the bolts for the hinge assembly are facing the bottom of the tower section and that the holes are on the opposite side of the tower leg that has the 3" and 4" mounting brackets (items 7, 8). See Figure 4.

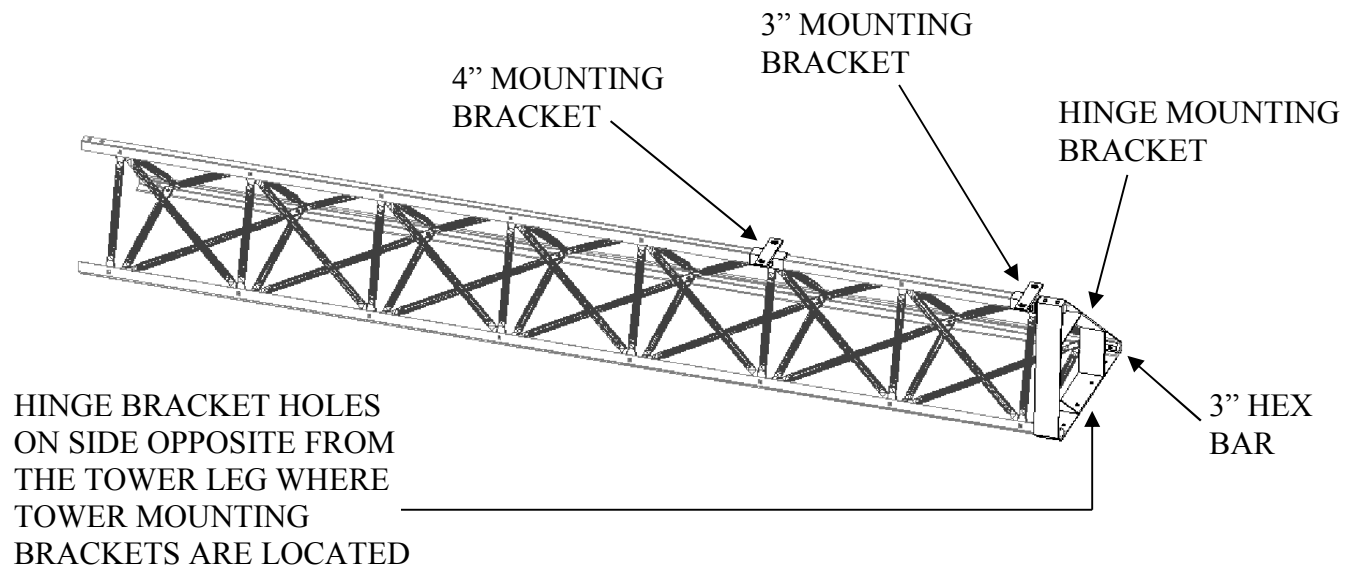

Figure 4 – Middle Tower Section with Brackets Mounted

7. Attach the two hinge brackets (item 10) with the hinge assembly (item 9) using $5/16'' \times 1''$ hardware (items 19, 21, 22). Ensure there is even spacing between the bottom and middle tower sections where the 3" hex spacer bars meet. See Figure 5.

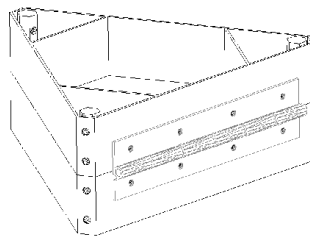

Figure 5 – Hinge Mounted on Hinge Bracket

8. Attach the lever pole (item 11) via the top two bracket tabs onto the middle tower section only using $3/8'' \times 1\ 1/4''$ hex bolts and hardware (items 23, 24, 25). Ensure that the holes in all three lever mounting brackets (items 7, 8) and the winch bracket (item 14) are aligned with the lever pole mounting tabs so it can be joined properly once the tower is standing. See Figure 6.

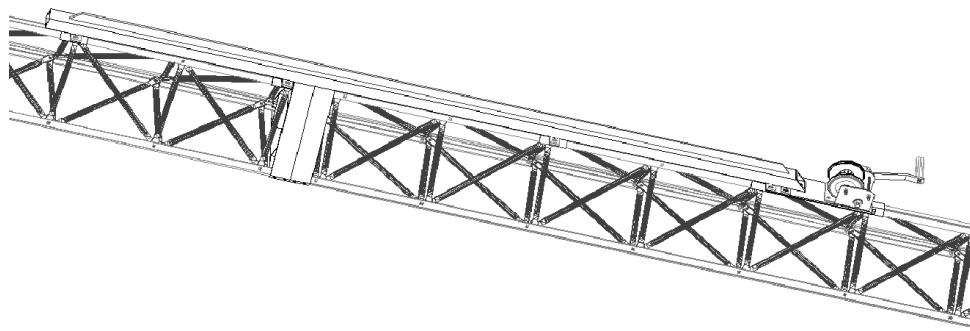

Figure 6 – Lever Pole Mounted on Tower Sections

9. Insert the winch cable (item 13) through the hole located at the bottom of the lever pole then onto the winch. Secure the winch cable onto the winch using provided winch hardware (see winch installation instruction sheet). Leave winch cable loose on winch for now.

10. The assembled tower is now ready to be joined with the tower base plate (item 17). All hardware on mounting brackets must be confirmed tight and secure before attaching the tower to the base. **(Note: this task should be performed by at least three people, or with the use of heavy machinery. The two attached tower sections are top-heavy; use proper caution when lifting it onto the tower base plate.)** Use 7/16" x 2 1/4" and 7/16" x 2 1/2" hex bolts and hardware (items 27, 28, 29, 30) to secure the bottom tower section to the tower base plate. See Figure 7.

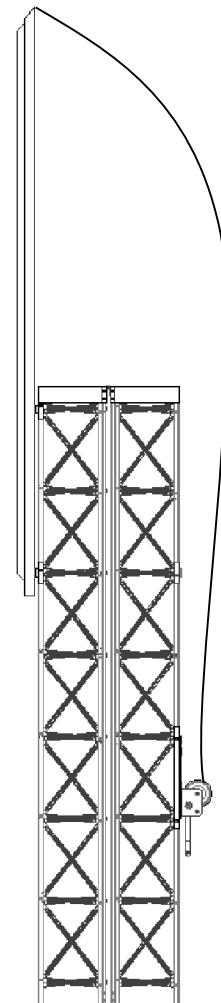

Figure 7 – Tower ready to be raised onto Base Plate

11. The top tower section (item 4) can be joined with the middle tower section using the 6" hex joiner bars (item 5) and 7/16" x 2" hex bolts and hardware (items 26, 29, 30). Insert the hex joiner bars into the top of the middle tower section with the 7/16" x 2" hex bolts and hardware (items 26, 29, 30). Do not tighten at this point.
12. Guide the top tower section to mate with the 6" hex joiner bars (item 5) using the 7/16" x 2" hex bolts and hardware (items 26, 29, 30). Tighten all hardware. See Figure 8.
13. At this point the tower functionality must be tested before attaching equipment to the tower. Raise the tower with use of the winch and cable. The top and middle tower sections should be raised and lowered with ease. Once vertical, ensure that the lever pole mounting tabs continue to be aligned with the brackets of the lower section (item 8, 11, 14), and that the pole is secured to the bottom tower section with 3/8" x 1 1/4" hex bolts and hardware (items 23, 24, 25).
14. A lock may be installed on the winch mounting bracket, through the elongated slot on the lower tab of the lever arm, to secure it further. (optional, not included)

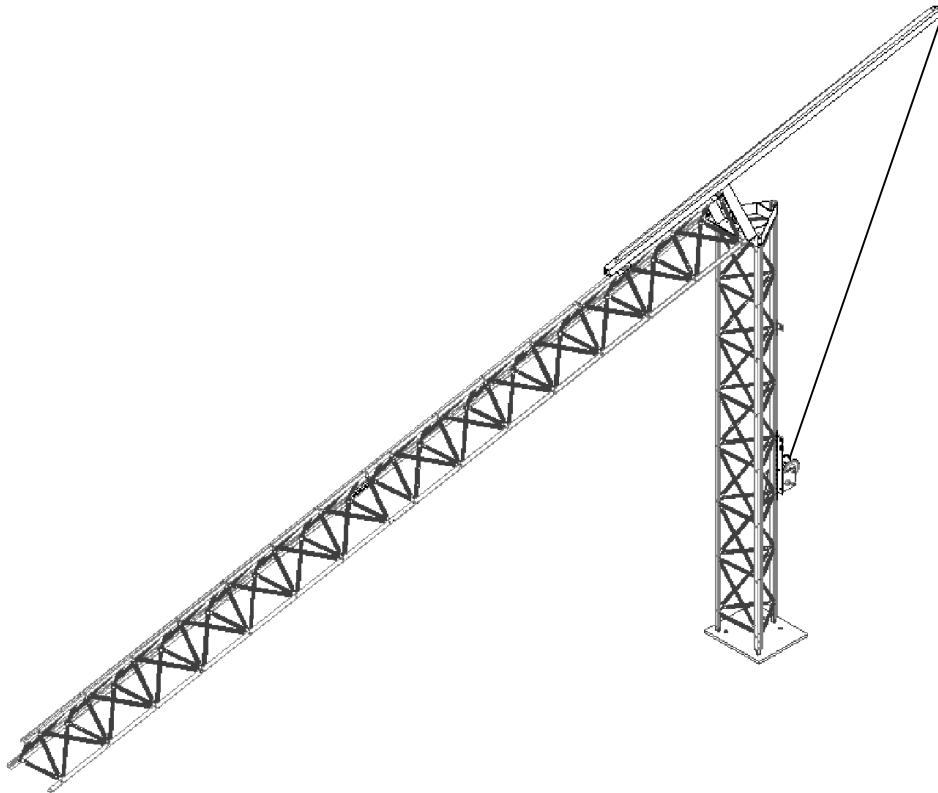

Figure 8 – Completed Tower (Folded Over)

RECOMMENDED ANCHOR BOLT TORQUE

The recommended anchor bolt tightening torque is the following:

Bolt diameter (inches)	Recommended torque (ft-lbs)
3/4"	100

TOWER MAINTENANCE

The tower must be visually inspected 4 weeks after installation and at intervals of 12 months thereafter. Hardware that has loosened due to temperature changes and wind action should be tightened.

Inspect the concrete foundation for cracks. Small cracks can be filled with grout to prevent any further degradation, and any large cracks must be reported to the engineer in charge. Also the base of the tower should be inspected for any evidence of bending and stress, which may have occurred.

The winch must also be inspected for proper functionality and ensure that the wire rope is well attached to the winch.

A report should be completed to record the findings.

APPENDIX A

PARTS LIST - DRAWING

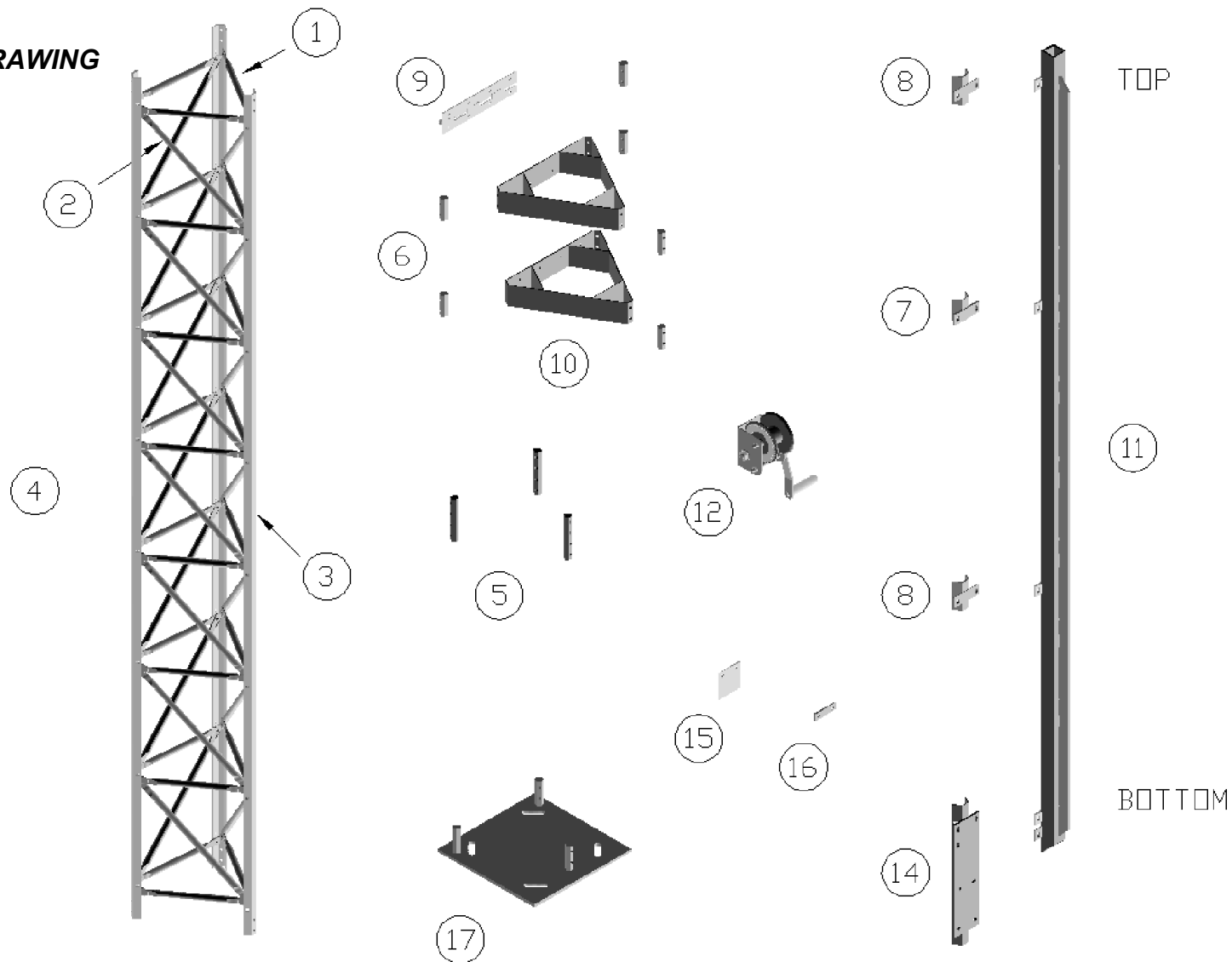

The information contained herein is proprietary to Approach Navigation Systems Inc and is used solely for the purpose for which it is supplied. It shall not be disclosed in whole or in part to any other party without the express permission in writing by Approach Navigation Systems Inc.

PARTS LIST

Item	Description	Quantity
1	15" short lattice bar	72
2	22" long lattice bar	63
3	tower leg	9
4	tower section	3
5	6" hex joiner bar	3
6	3" hex spacer bar	6
7	3" lever mounting bracket	1
8	4" lever mounting bracket	2
9	hinge assembly	1
10	hinge bracket	2
11	10' lever pole	1
12	winch	1
13	winch cable assembly	1
14	winch mounting bracket	1
15	winch plate	1
16	winch spacer plate	1
17	adjustable tower base	1
18	5/16" x 1 1/4" carriage bolt, stainless steel	144
19	5/16" x 1" hex bolt, stainless steel	8
20	5/16" x 1 1/2" hex bolt, stainless steel	10
21	5/16" flat washer, stainless steel	324
22	5/16" nylon lock nut, stainless steel	162
23	3/8" x 1 1/4" hex bolt, stainless steel	12
24	3/8" flat washer, stainless steel	24
25	3/8" nylon lock nut, stainless steel	12
26	7/16" x 2" hex bolt, stainless steel	24
27	7/16" x 2 1/4" hex bolt, stainless steel	3
28	7/16" x 2 1/2" hex bolt, stainless steel	3
29	7/16" flat washer, stainless steel	48
30	7/16" nylon lock nut, stainless steel	24
31	3/4" x 25" + 5" anchor J-bolt, galvanized	4
32	3/4" flat washer, galvanized	8
33	3/4" lock washer, stainless steel	4
34	3/4" x 2" x 2" square washer, galvanized	8
35	3/4" hex nut, galvanized	4

TOWER FOLDED AND UPRIGHT

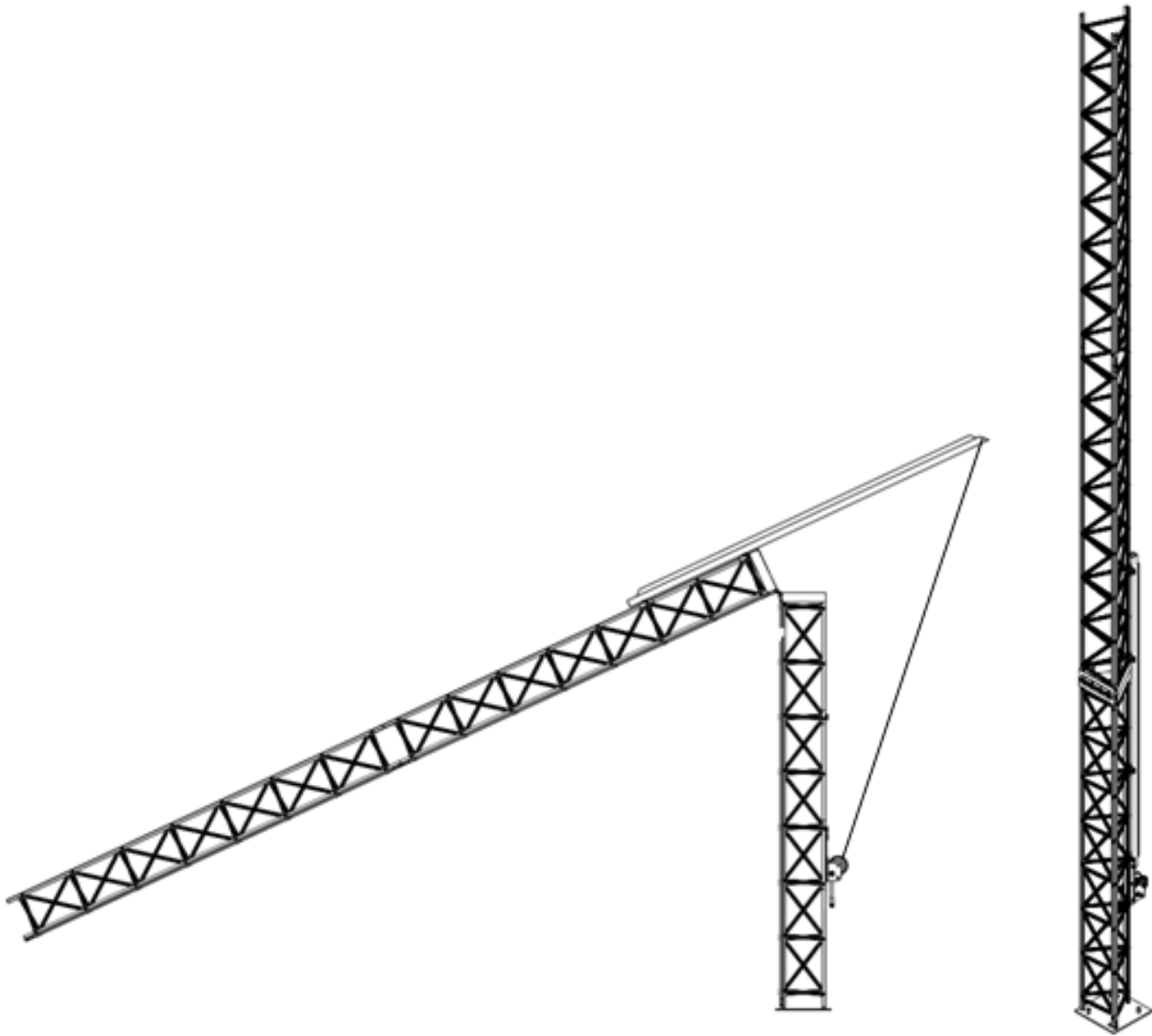

The information contained herein is proprietary to Approach Navigation Systems Inc and is used solely for the purpose for which it is supplied. It shall not be disclosed in whole or in part to any other party without the express permission in writing by Approach Navigation Systems Inc.